

FK Grease Lubrication Pump Unit

for use in progressive, single-line and dual-line
centralized lubrication systems

Assembly instructions acc. to EC Dir. 2006/42/EC
for partly completed machinery with associated operating instructions

EN



EC Declaration of Incorporation according to Machinery Directive 2006/42/EC, Annex II Part 1 B

The manufacturer SKF Lubrication Systems Germany GmbH ,Plaint Hockenheim, 2. Industriestraße 4, DE - 68766 Hockenheim hereby declares that the partly completed machinery:

Designation: **Grease Lubrication Pump Unit**
 Type: **AG. FK**
 Part no.: **774-***

Year of construction: See type identification plate
 complies with the following basic requirements of the EC Machinery Directive 2006/42/EC at the time when first being launched in the market.

1.1.2 · 1.1.3 · 1.3.2 · 1.3.4 · 1.5.1 · 1.5.6 · 1.5.8 · 1.5.9 · 1.6.1 · 1.7.1 · 1.7.3 · 1.7.4

The special technical documents were prepared following annex II part B of this directive. Upon justifiable request, these special technical documents can be forwarded electronically to the respective national authorities. The person empowered to assemble the technical documentation on behalf of the manufacturer is the head of standardization; see manufacturer's address.

Furthermore, the following directives and harmonized standards were applied in the respective applicable areas:

2011/65/EU RoHS II
 2014/30/EU Electromagnetic compatibility | Industry

Standard	Edition	Standard	Edition	Standard	Edition	Standard	Edition
DIN EN ISO 12100	2011	DIN EN 60947-5-1	2010	DIN EN 61000-6-2	2006	DIN EN 61000-6-4	2011
DIN EN 809	2012	DIN EN 61131-2	2008	Amendment	2011	DIN EN 60947-5-1	2010
DIN EN 60204-1	2007	Amendment	2009	DIN EN 61000-6-3	2011		
Amendment	2010	DIN EN 60034-1	2015	Amendment	2012		
DIN EN 50581	2013	DIN EN 61000-6-1	2007				

The partly completed machinery must not be put into service until the final machinery into which it is to be incorporated has been declared in conformity with the provisions of the EC Machinery Directive 2006/42/EC and any other applicable directives.

Hockenheim, 2016/04/25

Jürgen Kreuzkämper
 Manager R&D Germany
 SKF Lubrication Business Unit



Stefan Schürmann
 Manager R&D Hockenheim/Walldorf
 SKF Lubrication Business Unit



Grease lubrication pump units of the FK series

© SKF Lubrication Systems Germany GmbH

This documentation is protected by copyright. SKF Lubrication Systems Germany GmbH reserves all rights, including those to the photo-mechanical reproduction, duplication and distribution using special procedures (e.g., data processing, data media and data networks) of this documentation in whole or in part.

Subject to changes in contents and technical information.

Imprint

The assembly/operating instructions are an integral component of the described product and must be preserved for future use. The assembly instructions with associated operating instructions have been prepared in accordance with the established standards and rules for technical documentation VDI 4500 and EN 292.

Service

If you have technical questions, please contact the following addresses:

SKF Lubrication Systems Germany GmbH

Berlin Plant

Motzener Strasse 35/37
12277 Berlin Germany
Tel. +49 (0)30 72002-0
Fax +49 (0)30 72002-111
www.skf.com/lubrication

Hockenheim Plant

Industriestrasse 4
68766 Hockenheim Germany
Tel. +49 (0)62 05 27-0
Fax +49 (0)62 05 27-101
www.skf.com/lubrication

Inhaltsverzeichnis

Assembly instructions		Operating instructions	
1. Safety instructions	7	1. Safety instructions	24
2. Lubricants	8	2. Lubricants	24
2.1 General information	8	3. Transport and temporary storage	25
2.2 Selection of lubricants	8	3.1 Lubrication units	25
2.3 Approved lubricants	9	3.3 General notes	25
3. Overview	10	4. Assembly	26
4. Assembly	11	4.1 Information on assembly	26
4.1 Assembly drawing	11	4.2 Assembly of FK pump unit	26
4.2 General information	12	4.3 Dismantling and disposal	26
4.3 Assembly of pump unit	13	5. Design and function	27
4.4 Electrical motor connection	14	5.1 General information	27
4.5 Connection of ultrasonic sensor	18	5.2 Design	27
4.6 Connection of 3/2 directional solenoid valves	19	5.3 Functional description	28
4.7 Connection of radial piston pump	19	6. Commissioning	31
4.8 Notes on the CE marking	20	6.1 Condition on delivery	31
		6.2 Pre-commissioning information	31
		6.3 Commissioning	32
		6.4 Venting of pump elements	34
		6.5 Configuration of U2 ultrasonic sensor	35
		7. Shutdown	36
		7.1 Temporary shutdown	36
		7.2 Permanent shutdown	36
		8. Faults, causes and remedies	37
		8.1 Commissioning malfunctions	38
		8.2 Operational malfunctions.	39
		8.2 Operational malfunctions	40
		8.3 Malfunctions on fill level control	41
		9. Maintenance	42
		9.1 General information	43
		10. Technical data	44
		11. Wearing parts and spare parts	44

Explanation of symbols and signs

You will find these symbols, which warn of specific dangers to persons, material assets or the environment, next to all safety instructions in these operating instructions.

Please heed these instructions and proceed with special care in such cases. Please forward all safety instructions to other users.

Instructions placed directly on the machines/ grease lubrication pump units, such as:

- arrow indicators
 - labels for fluid connections
- must be followed and kept in fully legible condition.



You are responsible!

Please read the assembly and operating instructions thoroughly and follow the safety instructions.

Hazard symbols



General hazard

DIN 4844-W9



Electrical voltage/current

DIN 4844-W8



Burn risk



Danger of being drawn into machinery

Indicators used with safety instructions and their significance

Indicator	Use
Danger!	danger of bodily injury
Warning	danger of damage to property and the environment
Note	provides additional information

Informational symbols



Note

- prompts an action
- used for itemizing
- ➔ points out other facts, causes or consequences
- ☞ provides additional information

Assembly instructions according to Machinery Directive 2006/42/EC, Annex VI

The assembly instructions fulfill the Machinery Directive indicated above with regard to “partly completed machinery.” Partly completed machinery, which includes the product described herein, is only intended to be incorporated into or assembled with other machinery or other partly completed machinery or equipment, thereby forming machinery to which the above-mentioned Directive applies.

Intended use

The FK grease lubrication pump unit is used to supply centralized lubrication systems in vehicles, systems and machines. The pump unit delivers mineral oils or environmentally compatible oils from ISO VG 46 to greases of NLGI Grade 3. Consultation with a SKF Service Center is required for synthetic oils. Any other usage is deemed non-compliant with the intended use.

1. Safety instructions

General



Warning

These operating instructions must be read and properly understood by the assembler and the responsible technical personnel/operator before assembly and commissioning.

The FK grease lubrication pump unit is manufactured in accordance with the generally accepted rules and standards of industry practice, occupational safety and accident prevention regulations. Risks may, however, arise from its usage and may result in physical harm to the user or others and in damage to other material assets. The FK grease lubrication pump unit may only be used in proper technical condition and in observance of the assembly and operating instructions. In particular, any malfunctions which may affect safety must be remedied immediately.



Note

In addition to the operating instructions, general statutory regulations and other binding regulations for accident prevention and environmental protection (recycling/disposal) must be observed and applied.

Electric shock hazard

Only appropriately trained qualified personnel may establish electrical connections for the devices in observance of the local conditions for connections and local regulations (e.g., DIN, VDE). Significant bodily injury and property damage may result from improperly connected devices.

System pressure hazard

The systems may be pressurized. They must be depressurized before starting upgrades, changes or repairs.

Assembly work

When performing any assembly work on vehicles, machines and systems, the local accident prevention regulations as well as the specific operational and maintenance specifications are to be followed.

Authorized personnel

Only qualified personnel may install, operate, maintain and repair the components described in these instructions. Qualified personnel are persons who have been trained, assigned and instructed by the system operator. Such persons are familiar with the relevant standards, rules, accident prevention regulations and operating conditions as a result of their training, experience and instruction. They are authorized to identify and perform necessary actions while avoiding potential risks. The definition of qualified personnel and the prohibition against employing non-qualified personnel are laid down in DIN VDE 0105 and IEC 364.

2. Lubricants

2.1 General information



All products from SKF Lubrication Systems Germany GmbH may be used only for their intended purpose and in accordance with the information in the product's assembly instructions.

Intended use is the use of the products for the purpose of providing centralized lubrication/ lubrication of bearings and friction points using lubricants within the physical usage limits which can be found in the documentation for the devices, e.g. assembly instructions/operating instructions and the product descriptions, e.g. technical drawings and catalogs.

Hazardous materials of any kind, especially the materials classified as hazardous by CLP Regulation EC 1272/2008 may only be used to fill SKF centralized lubrication systems and components and delivered and/or distributed with the same after consulting with and receiving written approval from SKF.

No products manufactured by SKF Lubrication Systems Germany GmbH are approved for use in conjunction with gases, liquefied gases, pressurized gases in solution, vapors or such fluids whose vapor pressure exceeds normal atmospheric pressure (1013 mbar) by more than 0.5 bar at their maximum permissible temperature. Other media which are neither lubricant nor hazardous substance may only be fed after consultation and written approval from SKF Lubrication Systems Germany GmbH. SKF Lubrication Systems Germany GmbH considers lubricants to be a component of the system design which must be factored into the selection of components and the design of centralized lubrication systems. The lubricating properties of the lubricants are critically important in these considerations.

2.2 Selection of lubricants



Observe the instructions from the machine manufacturer regarding the lubricants that are to be used.



The amount of lubricant required at a lubrication point is specified by the bearing or machine manufacturer. It must be ensured that the required quantity of lubricant is provided to the lubrication point. The lubrication point may otherwise not receive adequate lubrication, which can lead to damage and failure of the bearing.

Selection of a lubricant suitable for the lubrication task is made by the machine/system manufacturer and/or the operator of the machine/system in cooperation with the lubricant supplier. The bearings/friction points that require lubrication, their expected load during operation and the expected ambient conditions are taken into account during selection in consideration of economic and environmental aspects.

Where necessary, SKF Lubrication Systems Germany GmbH supports customers in the selection of suitable components for feeding the selected lubricant and in the planning of the SKF lubrication system.

 SKF Lubrication Systems Germany GmbH supports customers in the selection of suitable components for feeding the selected lubricant and in the planning and design of a lubrication system. Please contact SKF Lubrication Systems Germany GmbH if you have further questions regarding lubricants. Lubricants can be laboratory tested for feedability (e.g., "bleeding") in centralized lubrication system applications. An overview of the lubricant tests offered by SKF Lubrication Systems Germany GmbH can be requested from the Service Center of SKF Lubrication Systems Germany GmbH.

2.3 Approved lubricants



Only lubricants approved for the product may be used. Unsuitable lubricants can lead to failure of the product and to property damage.



Different lubricants cannot be mixed, as mixing may result in damage and necessitate costly and complicated cleaning of the product/lubrication system. It is recommended that an indication of the lubricant in use be attached to the lubricant reservoir in order to prevent accidental mixing of lubricants.

The product described here can be operated using lubricants that meet the specifications in the technical data. Depending on the product design, these lubricants may be oils, fluid greases or greases. Oils and base oils may be mineral, synthetic and/or rapidly biodegradable. Consistency agents and additives may be added depending on the operating conditions. Note that in rare cases, there may be lubri-

cants whose properties are within permissible limit values but whose other characteristics render them unsuitable for use in lubrication systems. For example, synthetic lubricants may be incompatible with elastomers.

3. Overview

2.4 Lubricants and the environment

 Lubricants can contaminate soil and bodies of water. Lubricants must be properly used and disposed of. Observe the local regulations and laws regarding the disposal of lubricants.

It is important to note that lubricants are environmentally hazardous, flammable materials which require special precautionary measures during transport, storage and processing. Consult the Safety Data Sheet from the lubricant manufacturer for information regarding transport, storage, processing and environmental hazards of the lubricant that will be used.



Components of the unit	
Item	Description
1	Ultrasonic sensor
2	Lubricant reservoir
3	3/2 directional solenoid valve (optional)
4	Screw conveyor driveshaft
5	Radial piston pump
6	Electric geared motor
7	Electrical connection

4. Assembly

4.1 Assembly drawing

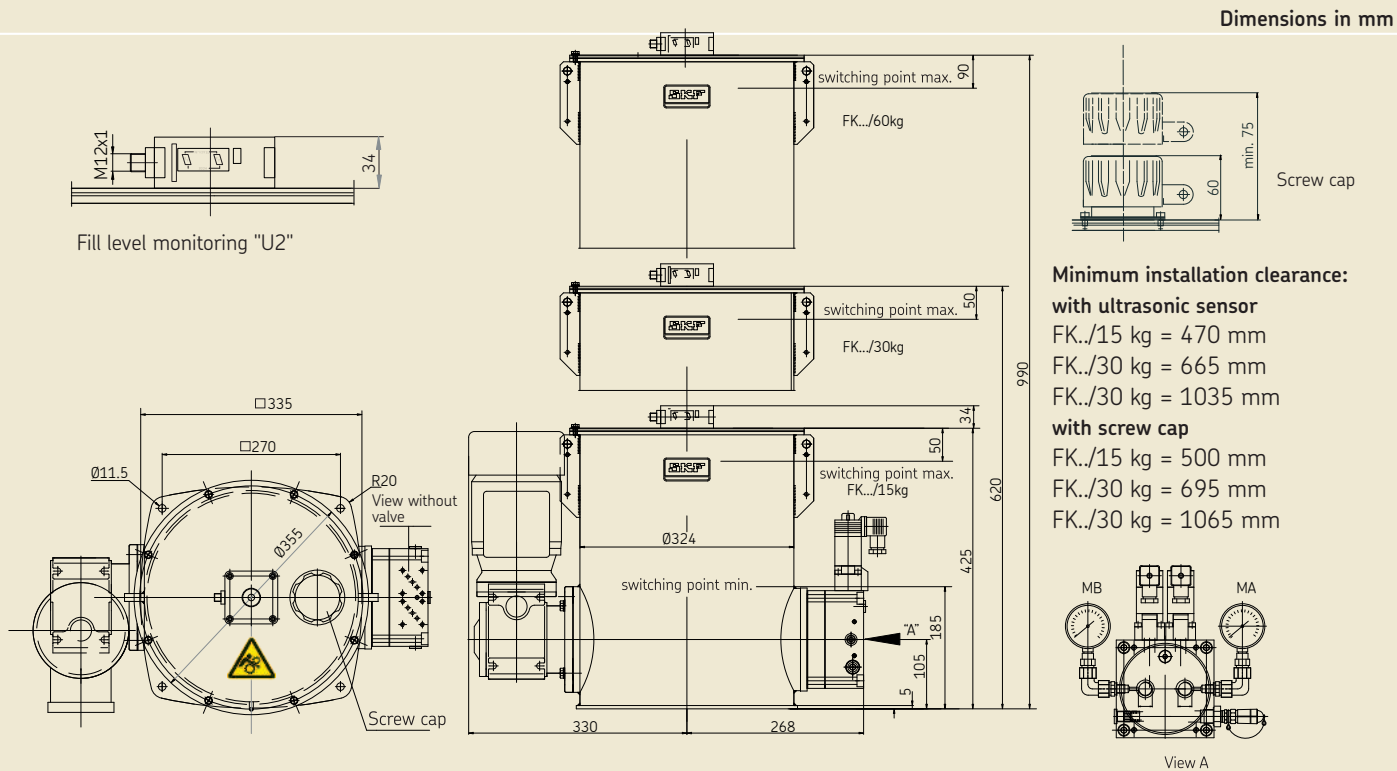

4.2 General information

4.2.1 Hydraulic line connection (General)

The hydraulic line must be connected to the lubrication unit in such a way that no forces can be transferred to the assembled lubrication unit (stress-free connection).



Warning

Before connecting the lubrication unit to the hydraulic supply, it must be ensured that the hydraulic supply is depressurized.



Warning

The maximum hydraulic oil pressure indicated for operating the hydraulically actuated lubrication unit may not be exceeded.

4.2.2 Lubrication line arrangement

Observe the following instructions when arranging the main lubricant lines and lubrication point lines in order to ensure that the entire lubrication system functions smoothly.

The main lubricant line must be dimensioned in accordance with the maximum pressure that occurs during operation and the delivery volume of the lubrication unit used. If possible, the main lubricant line should rise upward from the lubrication unit and be ventable at the highest point on the lubrication line system. Lubricant distributors at the end of the main lubricant line must be installed such that the lubrication point lines point upwards. If the system configuration requires that the lubricant distributors be arranged below the main lubricant line, they should not be placed at the end of the main lubricant line.

The pipes, tubes, shutoff valves and directional control valves, fittings, etc. that will be used must be designed for the maximum operating

pressure of the lubrication unit, the permissible temperatures and the lubricants that will be delivered. All components of the lubrication line system such as pipes, tubes, shutoff valves and directional control valves, fittings, etc. must be carefully cleaned before assembly. No seals should point inward in the lubrication line system, as this could hinder lubricant flow and introduce contaminants into the lubrication line system.

4.3 Assembly of pump unit

The FK grease lubrication pump unit must be installed on a level surface. The pump's base plate must not be under stress. Sufficient space must be provided during installation for later service and maintenance work.



Warning

The reservoir cover must be installed before turning on or commissioning the FK pump units. The rotating screw conveyor driveshaft may cause injury if the reservoir cover is not installed.



Warning

When drilling the assembly holes, you must be careful of any supply lines or other units, as well as of other hazards such as moving parts.

Maintain safety clearances and comply with local regulations for assembly and accident prevention.



Warning

Do not tilt or drop the FK grease lubrication pump unit!

The FK grease lubrication pump unit is installed using 4 screws (and washers). If M10 tapped bores are used to fasten the unit, the screws must have a minimum length of 20 mm.

Fastening material provided by the customer:

- Hexagon head screws (4x) acc. to DIN933-M10x20-8.8
- Washers (4x) acc. to DIN 125-B10.5-St

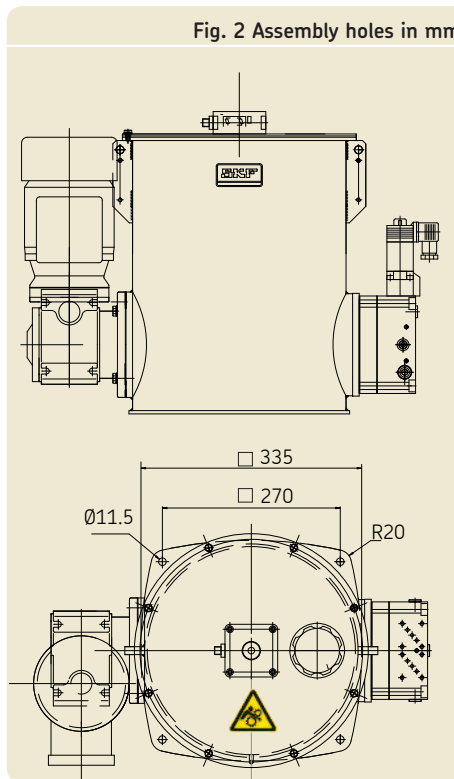

- Drill assembly holes (M10) acc. to assembly drawing (Fig. 2) and the conditions on the surface.
- Clean surface to remove drilling chips.
- Place the pump unit on the surface and roughly align it.
- Pass hexagon head screws (4x) acc. to (DIN933-M10x20-8.8) with associated washers (4x) acc. to DIN 125-B10.5-St through the fixing holes on the pump baseplate and apply the screws to the M10 threads on the surface.
- Gently tighten hexagon head screws (4x).
- Align pump unit, tighten hexagon head screws with following torque:
Torque 50 Nm

Fig. 2 Assembly holes in mm



4.4 Electrical motor connection



-see View Electrical motor connection, Page 16



	 WARNING
	<p>Electric shock</p> <p>Electrical connections for the product may only be established by qualified and personnel authorized to do so by the operator. The electrical operating conditions and local regulations (e.g., DIN, VDE) must be observed.</p>

Consult the motor's rating plate for the electrical characteristics of the motor. Observe the guidelines in EN 60034-1 (VDE 0530-1) for operation at the limits of the ranges A (combination of $\pm 5\%$ voltage deviation and $\pm 2\%$ frequency deviation) and B (combination of $\pm 10\%$ voltage deviation and $+3/-5\%$ frequency deviation). This applies especially with regard to deviations in operating parameters from the ratings on the motor's rating plate. The limits must never be exceeded.

Be sure to connect the motor so as to guarantee a continuously safe electrical connection (no protruding wire ends); use the assigned cable end fittings (e.g. cable lugs, wire end ferrules). Select connecting cables conforming to DIN VDE 0100 taking into account the rated current and the conditions of the specific system (e.g. ambient temperature, type of routing etc. in accordance with DIN VDE 0298 or EC/EN 60204-1).

Details regarding electrical connection of the Motor to the power supply, especially terminal and connector pin assignment, can be taken from the following motor data table or customer drawing (if available).

		WARNING
	Electric shock/damage to pump motor The available mains voltage (supply voltage) must match the specifications on the rating plate of the motor or of the electrical components. Check the fuse protection of the electrical circuit.	

		WARNING
	Damage to pump motor/pump When establishing the electrical connection of the pump motor, be mindful of the correct direction of rotation. The direction of rotation must match the arrow on the motor	

☞ The electrical connection diagram (2) for the motor is engraved in each case in the inside of the terminal box cover (3) or attached as a connection diagram in the terminal box.

- Connect pump unit motor according to the motor rating plate (1), motor characteristics (see following Pages) and connection diagram (2).

Motor connection

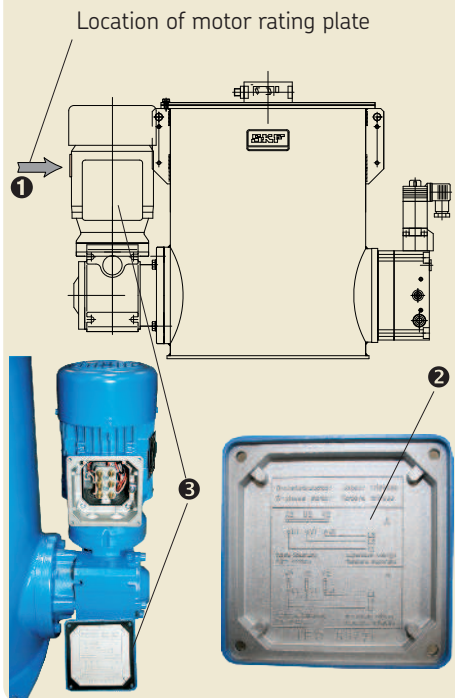

Technical Data		SKF-Engine Order No.		
		84-1731-4801	84-1731-4802	84-1731-4812
Admission				
Rated voltage	VAC	230/400 ± 10%	290/500 ± 10%	400/690
Frequency	Hz	50	50	50
Rated output	kW	0,37	0,37	0,37
Output speed	U/min	1380 /34	1500	1380/34
Output torque	Nm	62	62	62
Service factor		1,3	1,3	1,3
Reduction		40:1	40:1	40:1
Operating mode		S1	S1	S1
Insulation		F	F	F
Protection	IP	55	55	55
Transmission options				
Basic module part no.		60591400	60591400	60591400
Fange		FA/I	FA/I	FA/I
Motor mounting		B14 C105	B14 C105	B14 C105
Protector Cover		HA	HA	HA

Technische Daten		SKF-Motor-Bestellnummer		
		84-2731-5801	84-0020-4401 (Engine)	24-0701-3508 (Worm gear)
Admission				
Rated voltage	VAC	400/690	24 V DC	
Frequency	Hz	60		
Rated output	kW	0,37	160 W	
Output speed 1	A	1,10	$L_a = 6,4$ A	
Output speed 2	A	0,64	$L_e = 2,9$ A	
Cosinus	cos	10,8		
Output speed	U/min	1675/42	1000	
Output torque	Nm	51,6		
Service factor		1,6		
Reduction		40:1		80:1
Operating mode		S1		
Insulation		F		
Protection	IP	55		
Transmission options		Universal gear, Flange B5		Universal gear, Flange B5
Mounting cylinder		IEC71 B14 C105		IEC 71
Mounting flange cylinder	mm			105
Diameter flange	mm	160		160
Motor mounting			B14 C105	
Protector Cover		HB	HB	
Lubricant	ÖL	ISO VG 680		
Lubricant volume	L	0,095		

4.5 Connection of ultrasonic sensor

(ultrasonic fill level indicator)



Warning

Connect lines in accordance with the technical specifications and the local conditions for connections and local regulations (e.g., DIN, VDE).

- Connect U2 ultrasonic sensor as shown in the connection diagram and the rating plate (1).

Connection of U2 ultrasonic sensor

Standard symbol/connection:
(Version E6, pnp)

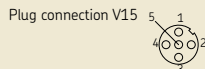
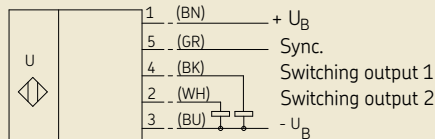

U2 ultrasonic sensor characteristics

TypeUltrasonic sensor, 2 adjustable switching points, max., min.

Sensing range60 to 1000 mm
 Adjustment range90 to 1000 mm
 Response delay.....approx. 150 ms
 Type of output2 pnp switching outputs,
 Choice of NO-contact/NC contact

Ambient temperature.....-25 °C to +70 °C

Display/Control elements

Yellow LED 1 constant:state of switching output 1 / flashing: teach-in function

Yellow LED 2 constant:state of switching output 2 / flashing: teach-in function

Red LED normal operation: "Fault" /
 Teach-in function: no object detected

Electrical data

Operating voltage.....10 to 30 V DC
 Ripple10% PP (peak-to-peak)

No-load current I_0 ≤ 50 mA
 Protection classIP 65
 ConnectionV15 connector socket (M12x1), 5-pin

4.6 Connection of 3/2 directional solenoid valves (reversing valves on pump designs FK1 and FK2)

- Connect 3/2 directional solenoid valve(s) acc. to connection diagram

Connection diagram for 3/2 directional solenoid valve

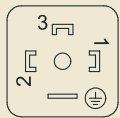

3/2 directional solenoid valve characteristics

Basic position	de-energized closed
Manual actuation	yes
Voltages	24 V DC
Rated current	0.67 A
Rated output	20 W
ON-time	100% ON-time (at max. +35°C)
Protection class	IP 65
Plug connection	DIN 43650-AF3

4.7 Connection of radial piston pump

(see operating instructions, Chapter 4)

All pump designs (F1, F2, F3 or F4) of the FK pump unit have the same pipe thread G1/2".

The G1/2" screw union and the downstream piping or tubing must correspond to the maximum permissible operating pressure for the pump unit. Depending on the pump usage and lubrication system (progressive, single-line or dual-line system), the maximum operating pressure can be 200 bar, 300 bar or 400 bar.

The specification for the factory-set maximum operating pressure is contained in the order number and should be obtained from the order confirmation. The rating plate can also be used for further verification. Item 8 of the type designation contains the max. operating pressure of 200 bar, 300 bar or 400 bar. SKF Lubrication Systems Germany GmbH recommends only choosing screw unions, pipes and tube connections from the heavy-duty series.

Screw unions on pump

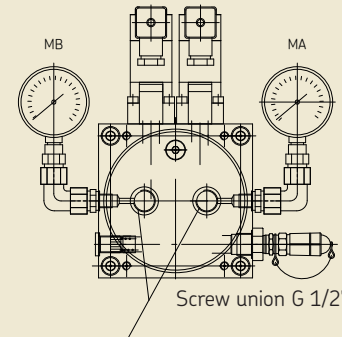

Labeling of max. operating pressure

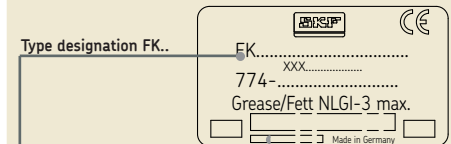

Example:
 FK 2 / 15 U2 1M 04 / 6 / 400 M2 3 / 0001 AF 07
 Item 8
 Operating pressure max:
 from 200 bar, 300 bar or 400 bar

Note on the rating plate

Rating plates on FK grease lubrication pump units provide important key data such as the type designation, order number, barcode and serial number.

To avoid loss of this data in case the rating plate becomes illegible, these characteristics should be entered in the following table.

- Enter key data from rating plate in the following table:

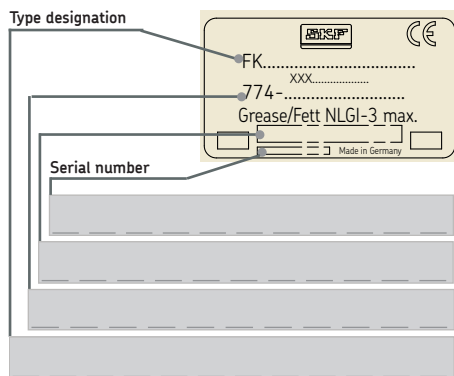

4.8 Notes on the CE marking

The CE marking is performed following the requirements stated in the applied standards:

- 2014/30/EU Electromagnetic Compatibility
- 2011/65/EU (RoHS II) Directive on the restriction of the use of certain hazardous substances in electrical and electronic equipment

Notes on the Low Voltage Directive

The protective regulations of the low voltage directive 2014/35/EU are complied with according to annex I, no. 1.5.1 of machinery directive 2006/42/EC.

Notes on the Pressure Equipment Directive 2014/68/EU

Due to its performance rates the product does not achieve the limit values fixed in article 4 (1)(a)(i) and is excluded from the scope of the pressure equipment directive 2014/68/EC article 4(3).



Warning

Information beyond the actual assembly procedure is contained in the included operating instructions. The assembly and operating instructions are therefore considered an inseparable part of the documentation.

The operating instructions are divided into the chapters:

1. Safety instructions
 2. Transport and temporary storage
 3. Assembly
 4. Design and function
 5. Commissioning
 6. Faults, causes and remedies
 7. Maintenance
 8. Technical data
 9. Wearing parts and spare parts
- (see Table of contents, Page 4)



These assembly instructions and the included operating instructions must be read and properly understood by the assembler and the responsible technical personnel/operator before assembly.

FK Grease Lubrication Pump Unit
for use in progressive, single-line and dual-line
centralized lubrication systems

Operating instructions associated

1. Safety instructions

General



Warning

These operating instructions must be read and properly understood by the assembler and the responsible technical personnel/operator before assembly and commissioning.

The safety instructions listed in Chapter 1, "Safety instructions," of the assembly instructions also apply without restrictions to these operating instructions.



Note

In addition to the operating instructions, general statutory regulations and other binding regulations for accident prevention and environmental protection (recycling/disposal) must be observed and applied.

Disclaimer of liability

SKF Lubrication Systems Germany GmbH shall not be held liable for damages:

- caused by contaminated or unsuitable lubricants
- caused by the installation of non-original SKF components or SKF spare parts
- caused by inappropriate usage
- resulting from improper assembly, configuration or filling
- resulting from improper response to malfunctions
- caused by independent modification of system components
- Only media approved for these types of pump units may be used. Unsuitable media may result in pump unit failure and potentially severe bodily injury and property damage.

2. Lubricants



Warning

The information on lubricants listed in Chapter 2, "Lubricants," of the assembly instructions also applies without restrictions to these operating instructions.

3. Transport and temporary storage

SKF Lubrication Systems Germany GmbH

products are packaged in accordance with standard commercial practice according to the regulations of the recipient's country and DIN ISO 9001. During transport, safe handling must be ensured and the product must be protected from mechanical effects such as impacts. The transport packaging must be marked with the "Do not drop!".



Warning

The product must not be tilted or dropped.

There are no restrictions for land, air or sea transport. After receipt of the shipment, the product(s) must be inspected for damage and for completeness according to the shipping documents. The packaging material must be preserved until any discrepancies are resolved. SKF Lubrication Systems Germany GmbH products are subject to the following storage conditions:

3.1 Lubrication units

- Ambient conditions: dry and dust-free surroundings, storage in well ventilated dry area
- Storage time: max. 24 months
- Permissible humidity: < 65%
- Storage temperature: 10 - 40°C
- Light: Avoid direct sun or UV exposure and shield nearby sources of heat

3.2 Electronic and electrical devices

- Ambient conditions: dry and dust-free surroundings, storage in well ventilated dry area
- Storage time: max. 24 months
- Permissible humidity: < 65%
- Storage temperature: 10 - 40°C
- Light: Avoid direct sun or UV exposure and shield nearby sources of heat

3.3 General notes

- The product(s) can be enveloped in plastic film to provide low-dust storage
- Protect against ground moisture by storing on a shelf or wooden pallet
- Bright-finished metallic surfaces, especially wearing parts and assembly surfaces, must be protected using long-term anti-corrosive agents before storage
- At approx. 6-month intervals: Check for corrosion. If there are signs of corrosion, reapply anti-corrosive agents.
- Drives must be protected against mechanical damage

4. Assembly

4.1 Information on assembly

The assembly procedure for FK pump units is described in detail in the assembly instructions associated with these operating instructions. Information/instructions about assembling the FK pump unit beyond the scope of the assembly instructions are contained later in this chapter.

4.2 Assembly of FK pump unit

Assembly must be performed in accordance with the included assembly instructions and the additional information/instructions contained in this chapter.

4.3 Dismantling and disposal



Warning

The applicable national environmental regulations and statutes are to be adhered to when dismantling and disposing of the grease lubrication pump unit.

The product can also be returned to SKF Lubrication Systems Germany GmbH for disposal, in which case the customer is responsible for reimbursing the costs incurred.

5. Design and function

5.1 General information

The FK pump unit is a multi-function piston pump whose modular design makes it very versatile.

The FK pump unit can be used as a progressive, single-line or dual-line pump unit with or without integrated reversing valves. The modular design of the pump also allows it to be retrofitted from one of the above-mentioned lubrication systems to another system. Retrofitting can only be performed by SKF Service and is therefore not described in these instructions.

5.2 Design

The FK grease lubrication pump unit, which was designed to handle demanding usage, is available in reservoir sizes of 15 kg, 30 kg and 60 kg. A screw conveyor driveshaft fastened to the geared motor drives the pump unit and feeds grease to the radial piston pump flanged to the opposite side. Depending on the delivery output required, the radial piston pump can be equipped with up to six pump elements (internally consolidated). Based on the application, the radial piston pump is supplied as a progressive, single-line or dual-line pump, with or without reversing function. Grease level monitoring is performed by an ultrasonic sensor. A sensor with maximum and minimum switching points is provided.

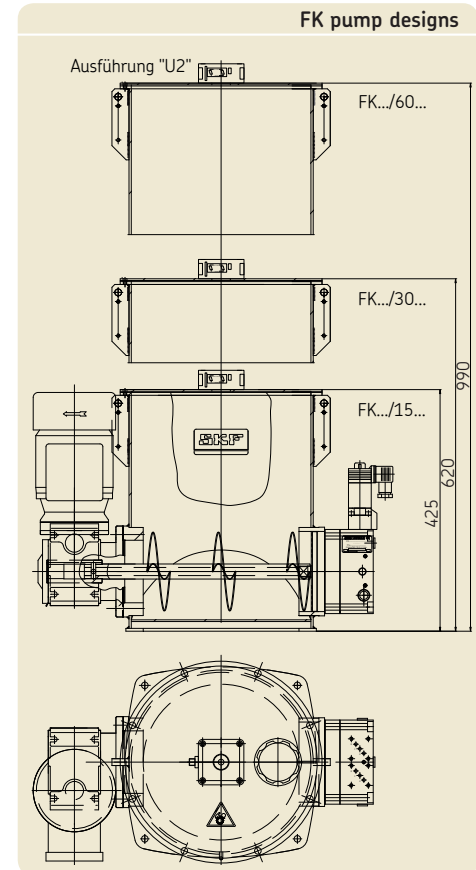

5.3 Functional description

The FK pump unit is driven by an electric geared motor (1) that is radially flanged to the left side of the reservoir. A screw conveyor driveshaft (2) flanged to the geared motor delivers the lubricant in the reservoir to the radial piston pump (3) on the opposite side of the reservoir and drives it as well. Piston stroke motions by the radial piston pump (3) are performed using a rotating eccentric shaft (4). Piston return (suction phase) is performed by positively driven pump pistons (5) that run in a plate cam (6). Depending on the volume of lubricant required, the radial piston pump can be equipped with up to six pump elements (7). Each pump element delivers the lubricant via its dedicated check valve (8) into a common downstream ring line (9). This protects the radial piston pump from potential pressure spikes. The further course of the lubricant depends on the specific pump application, i.e., whether it is used as a progressive, single-line or dual-line pump (see the following pump description for progressive, single-line or dual-line centralized lubrication systems).

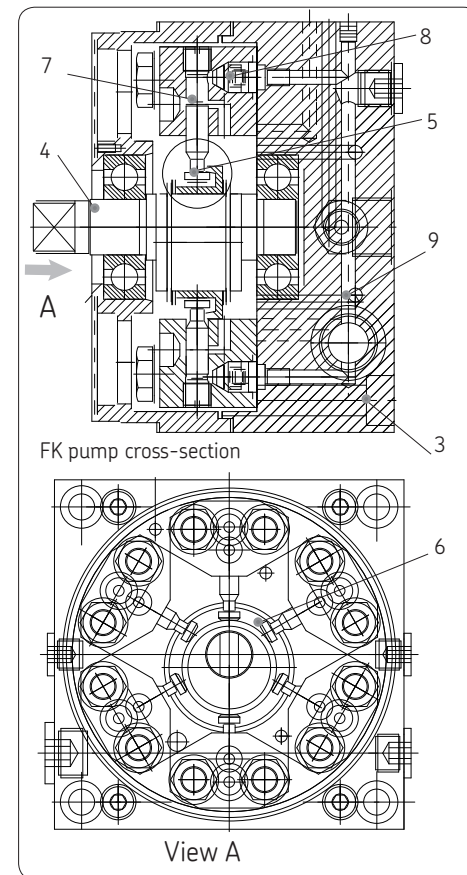

Pump unit for progressive centralized lubrication systems (FK4)

Lubricant that comes from the ring line (9) is delivered to pump outlet "A/P". From there it is passed to the downstream progressive feeders. The pump outlet "B/R" is closed on pump design FK4.

Pump unit for single-line centralized lubrication systems (FK1)

Lubricant that comes from the ring line (9) is delivered to the inlet of the 3/2 directional solenoid valve (10) flanged to the pump. The lubricant flows to pump outlet A/P if the directional solenoid valve is actuated. After this, the lubricant is passed on through the main lubricant line to the downstream single-line progressive feeders. When the 3/2 directional solenoid valve is in a de-energized state, pressure relief of the main lubricant line returns to the lubricant reservoir (T).

FK1 connection drawing

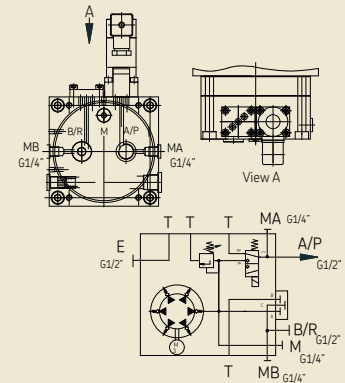

FK4 connection drawing

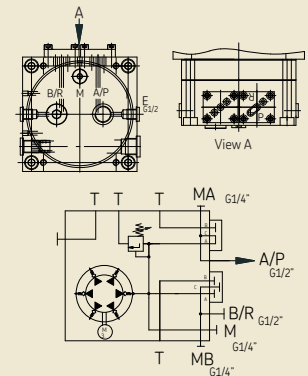

Pump unit for dual-line centralized lubrication systems without installed reversing valves (FK3)

Lubricant that comes from the ring line (9) is delivered to pump outlet "A/P". From there it is passed to the downstream external reversing valves. The pump outlet "B/R" serves to return the lubricant from the downstream changeover valve or pressure relief of one of the two main lines into the lubricant reservoir (T).

Pump unit for dual-line centralized lubrication systems with integrated reversing valves (FK2)

Lubricant that comes from the ring line (9) is delivered to the inlets of both 3/2 directional solenoid valves (10). If the 3/2 directional solenoid valve for connection A is actuated, the lubricant flows to outlet A. From there it is passed through the connected main lubricant line to the downstream dual-line distributors. At the same time, pressure in the second main lubricant line is relieved. This is performed via the second, non-actuated directional solenoid valve B and returns to the lubricant reservoir (T). When the required system pressure is reached, both directional solenoid valves switch over such that the main lubricant line that has been pressurized is relieved and the unpressurized main lubricant line is pressurized. In a de-energized state, both main lines are relieved.

FK3 connection drawing

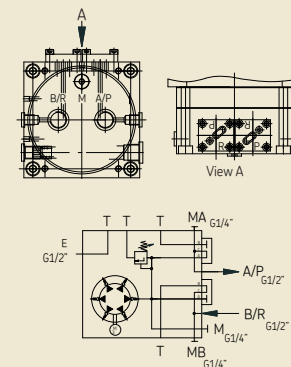

FK2 connection drawing

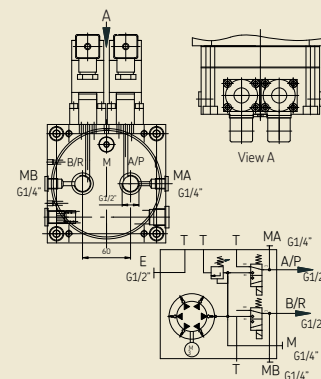

6. Commissioning

6.1 Condition on delivery

On delivery, the radial piston pump on the grease lubrication pump unit is already equipped with one to a maximum of six pump elements according to the required delivery volume. The grease lubrication pump has already been tested using oil and vented.

6.2 Pre-commissioning information



Warning

The reservoir cover must be installed before commissioning the FK pump units. The rotating screw conveyor driveshaft may cause injury if the reservoir cover is not installed.



Warning

The grease lubrication pump unit may only be filled via the filler socket. Filling through the reservoir cover may introduce air pockets and contaminate the fill level monitoring system, and is therefore not permitted.

The product described here functions automatically. The lubricant transport in the lubricant lines should, however, be

subjected to regular visual inspection. The lubricant fill level in the lubricant reservoir, if present, should likewise be subjected to regular visual inspection. If the lubricant fill level is too low, lubricant needs to be added up to the maximum mark as described in the "Commissioning" chapter.



Note

Observe the instructions from the machine manufacturer regarding the lubricants that are to be used.



Warning

Only fill using clean lubricant and an appropriate device. Contaminated lubricants can result in severe system malfunction. The lubricant reservoir must be filled without introducing bubbles.



Warning

Different lubricants cannot be mixed, as mixing may result in damage and necessitate costly and complicated cleaning of the product/lubrication system. It is recommended that an indication of the lubricant in use be attached to the lubricant reservoir in order to prevent accidental mixing of lubricants.

6.3 Commissioning

Reservoir cover and filler socket

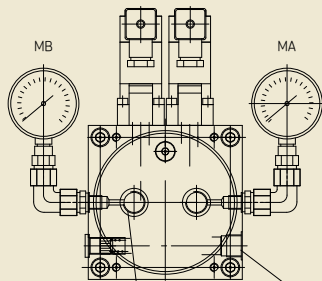
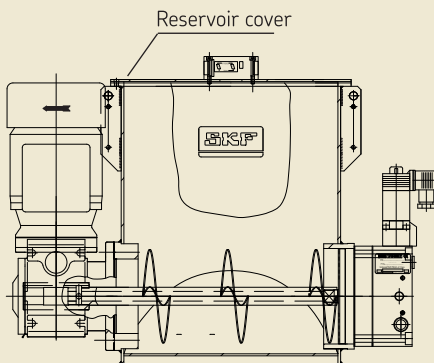

Filler socket G 1/2"

Before the product is commissioned, all electrical, hydraulic and pneumatic (if present) connections must be inspected. The lubricant may only be fed without bubbles. The lubricant reservoir, if present, must be filled with clean lubricant without introducing bubbles. The product is then operated until lubricant without bubbles is discharged at all lubrication points. The process of venting the lubrication system can be facilitated by:

- ☞ Performing initial commissioning only without lubricant lines connected
- Filling the FK grease lubrication pump unit with lubricant via the filler socket
- Connecting electrical connections and electrical lines in accordance with the technical specifications (rating plate) and the local conditions for connections and local regulations



Warning

The direction of driveshaft rotation is indicated on each pump unit by an arrow on the pump motor. The direction of rotation must match the arrow.

- Switch on the FK grease lubrication pump unit briefly (approx. 1 second).
- Check the direction of motor rotation based on the arrow attached to the motor housing.

Arrow indicator on pump motor

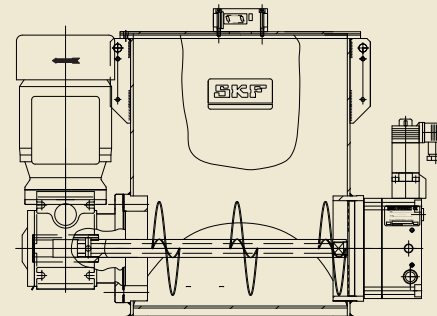

- ☞ The following procedure varies based on the pump unit design.

FK4 (for progressive systems)

- ☞ see FK4 connection drawing on Page 25

- ☞ After several minutes (depending on the number of installed pump elements), bubble-free grease should discharge from pump outlet "P". If this does not occur, the pump must be vented again as described in Chapter 6.4.

FK3 (for dual-line centralized lubrication systems with separate changeover valves)

- ☞ see FK3 connection drawing on Page 26

- ☞ After several minutes (depending on the number of installed pump elements), bubble-free grease should discharge from pump outlet "P".
If this does not occur, the pump must be vented again as described in Chapter 6.4.

FK1 (for single-line centralized lubrication systems)

- ☞ see FK1 connection drawing on Page 25

☞ Prerequisite:

The 3/2 directional solenoid valve must be connected and switched to pass-through ("A" to "P").

- ☞ After several minutes (depending on the number of installed pump elements), bubble-free grease should discharge from pump outlet "P".

If this does not occur, the pump must be vented again as described in Chapter 6.4.

FK2 (for dual-line centralized lubrication systems with changeover valves attached to pump)

- ☞ see FK2 connection drawing on Page 26

☞ Prerequisite:

Both 3/2 directional solenoid valves must be connected; if the directional solenoid valve with A/P connections is switched to

connection A, bubble-free grease must discharge from outlet A.

If the directional solenoid valve with B/R connections is switched to connection B, bubble-free grease must discharge from outlet B.

- ☞ After several minutes (depending on the number of installed pump elements), bubble-free grease should discharge from pump outlet "A" or "B".

If this does not occur, the pump must be vented again as described in Chapter 6.4. Repeat procedure with directional solenoid valves switched to opposite connections.

- Turn off FK grease lubrication pump unit

6.4 Venting of pump elements

- Remove screw unions (or pressure gauge screw) from connection MB (1)
- Allow FK pump unit to run until grease without bubbles discharges from the hole for connection MB
- Apply screw unions (or pressure gauge screw) to connection MB
- Tighten screw unions (or pressure gauge screw)

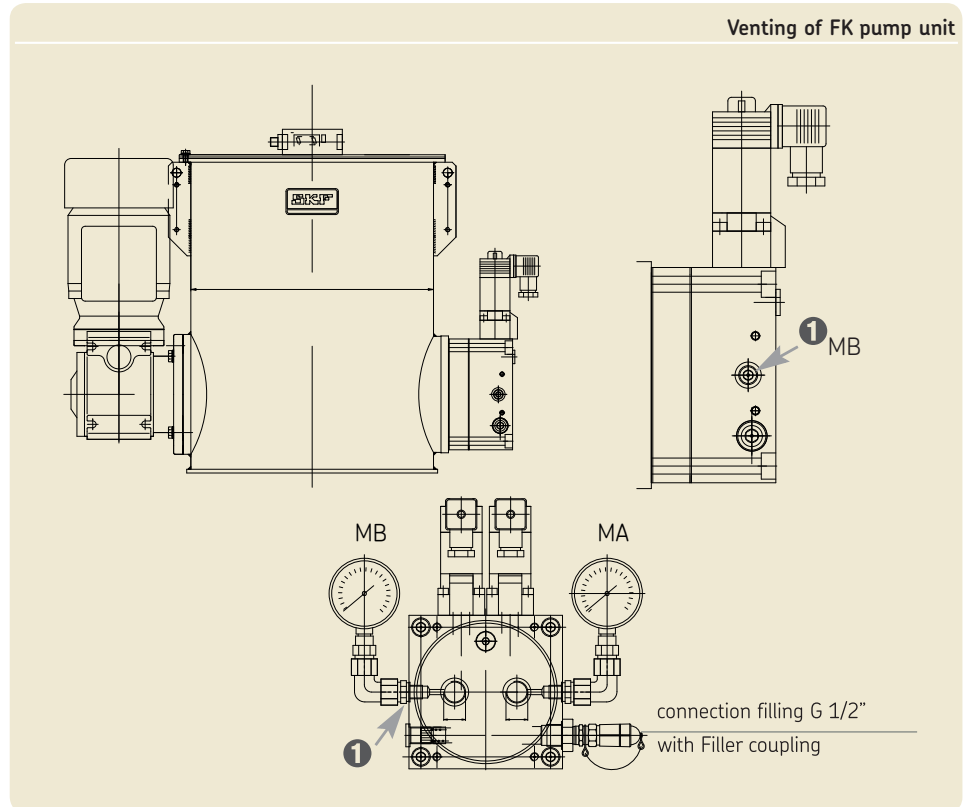

6.5 Configuration of U2 ultrasonic sensor



Warning

The max./min. switching points are factory-set based on the reservoir size of the pump unit. If the switching points need to be adjusted by the user, the parameters must be set as described below.

Parameterization

The sensor parameters can be set using two buttons. Button A_1 is used to start the teach-in mode for switching point 1, and button A_2 is used to start the teach-in mode for switching point 2. The sensor switches to sensitivity adjustment mode if both buttons are pressed when the power is turned on. If parameterization is not completed within five minutes, the sensor terminates the procedure and leaves the settings unchanged.

Teaching-in of switching points:

Teaching-in switching point A_1 (maximum with button A_1)

- Press membrane button A_1 >2 s
The sensor enters teach-in mode for switching point 1 (A_1)
- Position the target object at the desired distance
- ☞ The sensor's LEDs show whether the target object is detected. When the object is detected, the yellow LED flashes; when it is not detected, the red LED flashes.
- Briefly press membrane button A_1
- ☞ The sensor ends the teach-in procedure for switching point 1 and saves the value in non-volatile memory. The taught-in value is invalid in case of an uncertain object (red LED flashes irregularly). The teach-in mode is left.

The teach-in procedure for switching point A_2 (minimum) is performed using button A_2

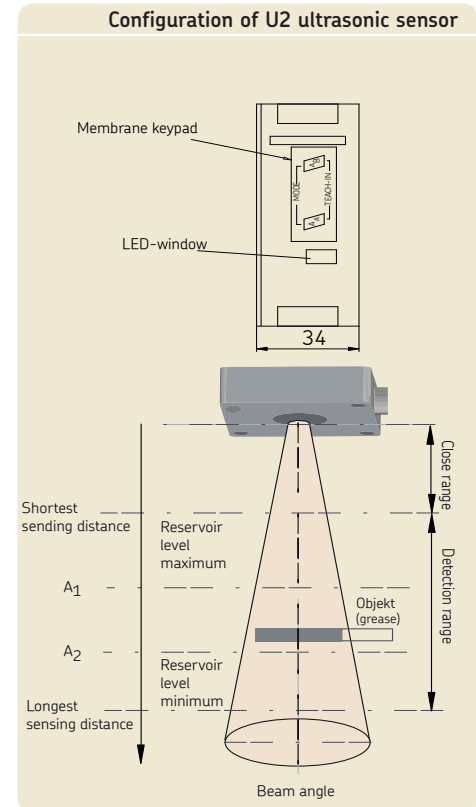

7. Shutdown

7.1 Temporary shutdown

The described product is temporarily shut down by disconnecting the electrical, pneumatic and/or hydraulic supply connections. The safety instructions in these assembly instructions must be observed.

If the product will be shut down for an extended period of time, the instructions in Chapter 3, "Transport and storage," of these operating instructions must be observed. If the product is recommissioned, the instructions in the Chapters "Assembly" and "Commissioning" in the assembly instructions and operating instructions must be observed.

7.2 Permanent shutdown

If the product will be permanently shut down, the local regulations and laws regarding the disposal of contaminated equipment must be observed. Lubricants can contaminate soil and bodies of water.



Warning

Lubricants must be properly used and disposed of. Observe the local regulations and laws regarding the disposal of lubricants.

8. Faults, causes and remedies

The following tables provide an overview of possible malfunctions and their causes. Contact the Service department of SKF Lubrication Systems Germany GmbH if you cannot remedy the malfunction.



Note

Dismantling of the product or individual parts thereof within the statutory warranty period is not permitted and voids any claims.



Note

All assembly, maintenance and repair work beyond this scope must be performed by **SKF Lubrication Systems Germany GmbH Service**.



Note

Only original spare parts from **SKF Lubrication Systems Germany GmbH** may be used. Arbitrary alterations to products and the use of non-original spare parts and accessories are not permitted.



Warning

Work on products that have not been de-energized may result in bodily injury. Assembly, maintenance and repair work may only be performed on products that have been de-energized by qualified technical personnel. The supply voltage must be switched off before opening any of the product's components.



Warning

The hot surface of a motor may cause burns. Motor surfaces may only be touched with appropriate gloves or after the motor has been shut off for an extended time.



Warning

Lubrication systems are pressurized during operation. Lubrication systems must be depressurized before starting assembly, maintenance or repair work as well as system modifications or system repairs.

8.1 Commissioning malfunctions

Commissioning malfunctions

Malfunction	Cause	Remedy
Delivery volume and/or delivery pressure too low without supply lines connected	Air in the pump element	● Vent and fill according to Chapter 5, Commissioning
	Driveshaft rotating in wrong direction	● Check electrical connections and voltage
No delivery (with pipe connections and supply lines not yet connected)	Air in the pump element	● Vent and fill according to Chapter 5, Commissioning
	Drive motor does not run	<ul style="list-style-type: none"> ● Check electrical connections ● Clean venting slots on motor ● Replace geared motor if necessary

8.2 Operational malfunctions

Operational malfunctions, Table 1 of 2

Malfunction	Cause	Remedy
Delivery volume or delivery pressure too low without lines connected	Air in the pump element	<ul style="list-style-type: none"> ● Vent and fill according to Chapter 6.4
	Pump element is clogged	<ul style="list-style-type: none"> ● See "No delivery" malfunction
	Driveshaft speed is too low	<ul style="list-style-type: none"> ● Check electrical connections and motor voltage ● Remove foreign substances if screw conveyor is jammed ● Permissible operating temperature range of -25 °C to + 60 °C not maintained ● Replace defective motor
	Pump element on radial piston pump defective	<ul style="list-style-type: none"> ● SKF Service - Remove and clean radial piston pump
	Check valve on radial piston pump defective or clogged	<ul style="list-style-type: none"> ● Vent and fill according to Chapter 6
No delivery	On designs F1 and F2 3/2 directional solenoid valve does not switch over completely	<ul style="list-style-type: none"> ● Disassemble and clean 3/2 directional solenoid valve, replace if necessary
	The lubricant's field of application does not correspond to the external conditions (temperature range)	<ul style="list-style-type: none"> ● Change lubricant
	Pump element is clogged	<ul style="list-style-type: none"> ● Empty and clean lubricant reservoir ● SKF Service - Remove and clean radial piston pump with pump element ● Vent and fill according to Chapter 6

8.2 Operational malfunctions

Operational malfunctions, Table 2 of 2

Malfunction	Cause	Remedy
No delivery	Pump element is defective	<ul style="list-style-type: none"> ● SKF Service - Remove radial piston pump, replace pump element ● Vent and fill according to Chapter 6
	Pressure relief valve is leaky	<ul style="list-style-type: none"> ● SKF Service - Clean or replace pressure relief valve in the radial piston pump
	Drive motor does not run	<ul style="list-style-type: none"> ● Check supply voltage, replace geared motor if necessary
	Cylindrical pin on screw conveyor broken, no pump drive	<ul style="list-style-type: none"> ● Remove radial piston pump, remove screw conveyor, apply new cylindrical pin to screw conveyor Remove broken cylindrical pin parts from pump, install screw conveyor and radial piston pump
	Fill level monitoring (U2) configured incorrectly	<ul style="list-style-type: none"> ● Reconfigure fill level monitoring
On designs F1 and F2 3/2 directional solenoid valve does not switch	<ul style="list-style-type: none"> ● Inspect connections on directional solenoid valves for proper seating ● Inspect 3/2 directional solenoid valve for proper function (solenoid), replace if necessary ● Check control of directional solenoid valves for proper run time function ● Clean internal parts 	

8.3 Malfunctions on fill level control (ultrasonic sensor)

Fill level control malfunctions

Malfunction	Cause	Remedy
No output signal	Screw connection of U2 ultrasonic sensor to cable box is loose	● Screw on cable box
	Switching points are no longer programmed into the ultrasonic sensors or are set incorrectly	● Reconfigure (teach) switching points (maximum, (minimum pre-warning), minimum) - see Chapter 6.5
	Ultrasonic sensor is contaminated	● Dismantle and clean ultrasonic sensor
	Ultrasonic sensor is defective	● Replace ultrasonic sensor
Grease reservoir not filled to maximum	Ultrasonic sensor calibrated incorrectly	● Reconfigure (teach) switching points maximum, (minimum pre-warning, minimum)
Pump switches off before reaching minimum	Ultrasonic sensor calibrated incorrectly	● Reconfigure (teach) switching points minimum, (minimum pre-warning, maximum) - see Chapter 6.5

9. Maintenance



Warning

Work on products that have not been de-energized may result in bodily injury. Assembly, maintenance and repair work may only be performed on products that have been de-energized by qualified technical personnel. The supply voltage must be switched off before opening any of the product's components.

SKF Lubrication Systems Germany GmbH products are low-maintenance. However, all connections must be regularly inspected for proper seating to ensure proper function and avoid hazards in the first place.

If necessary, the product can be cleaned using mild cleaning agents that are compatible with the product's materials (non-alkaline, non-soap). For safety reasons, the product should be disconnected from the power supply and the hydraulic and/or compressed air supply.

It must be ensured that no cleaning agent enters the interior of the product during cleaning.

It is not necessary to clean the interior of the product if the product is operated normally and intercompatible lubricants are used.

The interior of the product must be cleaned if incorrect or contaminated lubricant is accidentally filled into the product. Please contact the Service department of SKF Lubrication Systems Germany GmbH for assistance.



Note

Dismantling of the product or individual parts thereof within the statutory warranty period is not permitted and voids any claims.



Note

Only original spare parts from SKF Lubrication Systems Germany GmbH may be used. Arbitrary alterations to products and the use of non-original spare parts and accessories are not permitted and nullify the statutory warranty.

SKF Lubrication Systems Germany GmbH shall not be held liable for damages resulting from improperly performed assembly, maintenance and repair work on the product.

9.1 General information

Grease lubrication pump units of the FK series are generally maintenance-free. In order to prevent malfunctions due to external forces, a visual inspection should, however, be performed every 100 operating hours. The pump

unit must be switched off during the inspections. Maintenance work beyond this scope must be performed by SKF Service personnel.

Visual inspection every 100 operating hours

Item	Component	Inspection
1	Geared motor	Inspect fan slots on fan impeller for contamination
1+2	Radial piston pump on geared motor	Inspect for loosened screw unions
1+2	Radial piston pump on geared motor	Inspect for undesired grease discharge
3+4	Directional solenoid valves/Ultrasonic sensor	Inspect for loose cable connections and damage
5	FK pump unit	Inspect for contamination and damage



Warning

Only fill with clean grease. The purity of the lubricants used is the decisive factor in the service life of the pump and the lubricated machinery elements.

Only fill grease via the filler socket.

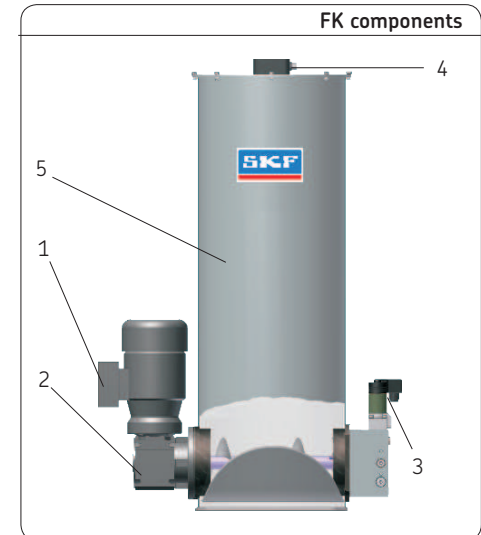

10. Technical data

FK characteristics

General

Mounting position vertical
 Ambient and lubricant
 temperature range .. -25 °C to + 60 °C
 Reservoir for 15 kg, 30 kg or 60 kg
 Number of pump elements 1 to 6
 Filling via filler socket G 1/2"
 Dry weight with reservoir capacity:
 15 kgapprox. 46.2 kg;
 30 kgapprox. 52.3 kg;
 60 kgapprox. 64.0 kg

Gears

TypeScrew drive, type **1M**
 Gear ratios 40:1

Pump

TypeRadial piston pump
 Pump outlet/inlet ...A/P and B/R
 Pipe threadG1/2"
 Operating pressure ...max. 400 bar

Delivery volume with: kg/hour

1 pump element.....	0.67
2 pump elements	1.34
3 pump elements	2.00
4 pump elements	2.64
5 pump elements	3.34
6 pump elements	4.00

Lubricants

Mineral oils or environmentally compatible oils
 from ISO VG 46 to greases of NLGI Grade 3
 (consultation required for synthetic oils)

Operating viscosity(oil) $\geq 50 \text{ mm}^2/\text{s}$
 Worked penetration ..(grease) $>220 \text{ }^{1/10} \text{ mm}$

11. Wearing parts and spare parts

Spare parts list for FK pump units

Item	Quantity	Description	Spare part number
1	1	Radial piston pump with pressure regulating valve: with 1 pump element	24-1557-4001
		with 2 pump elements	24-1557-4002
		with 3 pump elements	24-1557-4003
		with 4 pump elements	24-1557-4004
		with 5 pump elements	24-1557-4005
		with 6 pump elements	24-1557-4006
2	1	Screw conveyor driveshaft	24-2252-2028
3	1	Cylindrical pin	DIN 6325-8M6x28
4	1	Washer kit for reservoir-motor/reservoir-pump	24-0404-2616
5	1	Worm gear drive motor - see Order No page 16 to page 17	
7	1	Pressure gauge 400 bar	169-140-001
	1	Pressure gauge 600 bar	169-140-002
8	1	Filler coupling	995-000-705
9	1	3/2 directional solenoid valve 24 VDC	24-1254-2222
	1	3/2 directional solenoid valve 230 VAC	24-1254-2577
10	1	Connector socket 24-230 VAC/DC	24-1882-2167
11	1	U2 ultrasonic sensor with 2 switching points for reservoir sizes 15 kg and 30 kg	24-1884-2491
		for reservoir size 60 kg	24-1884-2490

Spare parts drawing for FK pump units

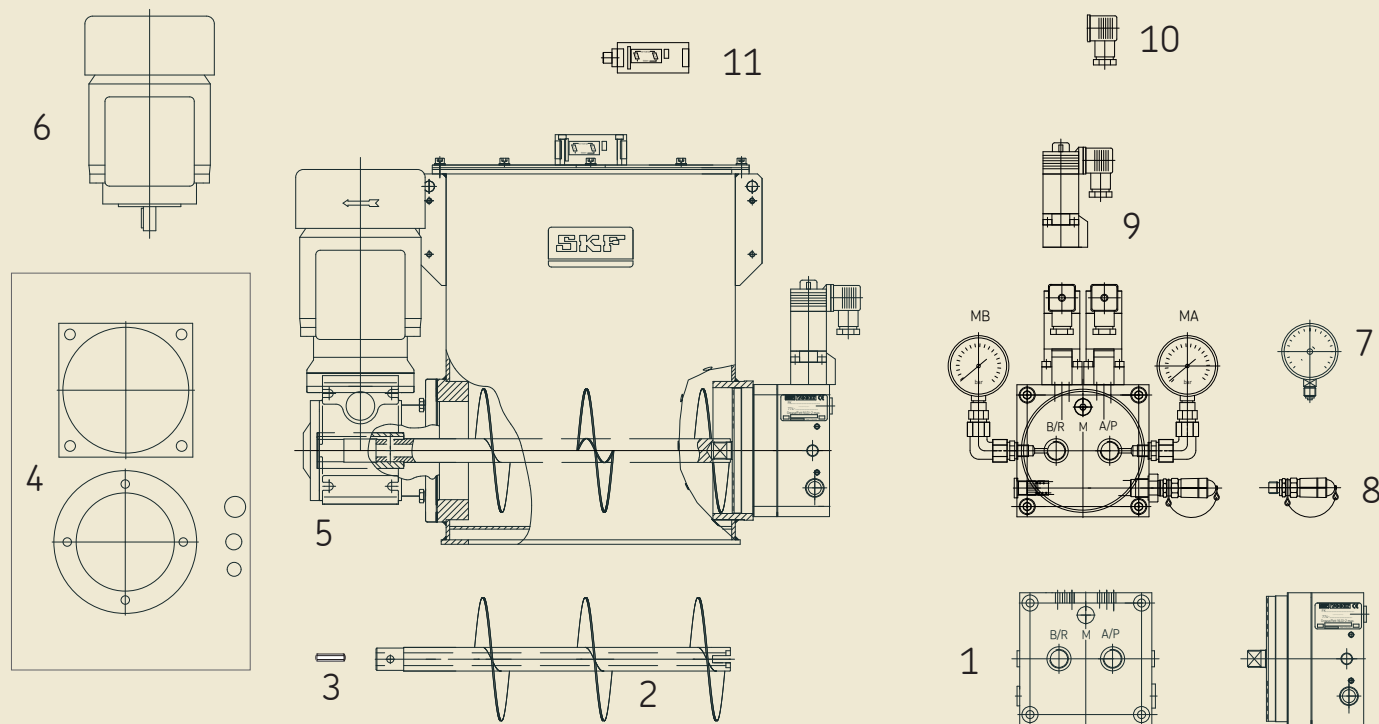

951-170-200-EN

Version 04

February 2019

The contents of this publication are the copyright of the publisher and may not be reproduced in whole or in part without permission of SKF Lubrication Systems Germany GmbH. Every care has been taken to ensure the accuracy of the information contained in this publication. However, no liability can be accepted for any loss or damage, whether direct, indirect or consequential arising out of use of the information contained herein.

All SKF products may be used only for their intended purpose as described in these assembly instructions with associated operating instructions. If assembly/operating instructions are supplied together with the products, they must be read and followed. Not all lubricants can be fed using centralized lubrication systems. SKF can, on request, inspect the feedability of the lubricant selected by the user in centralized lubrication systems. Lubrication systems and their components manufactured by SKF are not approved for use in conjunction with gases, liquefied gases, pressurized gases in solution, vapors or such fluids whose vapor pressure exceeds normal atmospheric pressure (1013 mbar) by more than 0.5 bar at their maximum permissible temperature.

Hazardous materials of any kind, especially the materials classified as hazardous by CLP Regulation EC 1272/2008 may only be used to fill SKF centralized lubrication systems and components and delivered and/or distributed with the same after consulting with and receiving written approval from SKF.

SKF Lubrication Systems Germany GmbH

Motzener Strasse 35/37 · 12277 Berlin · Germany

PF 970444 · 12704 Berlin · Germany

Tel. +49 (0)30 72002-0 · Fax +49 (0)30 72002-111

www.skf.com/lubrication

SKF Lubrication Systems Germany GmbH

2. Industriestraße 4 · 68766 Hockenheim · Germany

Tel. +49 (0)62 05 27-0 · Fax +49 (0)62 05 27-101

www.skf.com/lubrication

